

**Application**

This special insert Ensat®-SBS was developed primarily for applications in which chips – created by the self-tapping process – exert a detrimental effect and could cause serious damage or failure during subsequent operation of the installed assembly – for example in electronic equipment.

The three cutting bores distributed around the periphery are formed as chip reservoirs.

The coarse chips created during the installation process are stored in these reservoirs and cannot drop into sensitive equipment components.

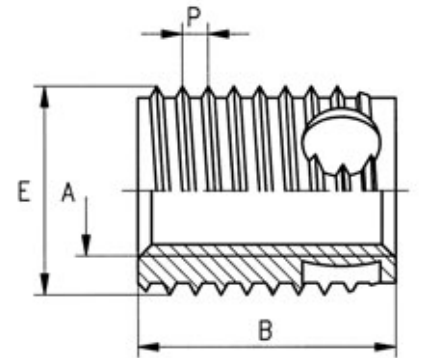

Dimensions in mm

Article number	Internal thread	External thread Special thread		Length	Borehole diameter guideline value	Minimum borehole depth for blind holes
	A	E	P		L -0,1	T
337 000 030 ...	M 3	5	0,6	4	4,8	6
338 000 030 ...	M 3	5	0,6	6	4,8	8
337 000 035 ...	M 3,5	6	0,8	5	5,7	7
338 000 035 ...	M 3,5	6	0,8	8	5,7	10
337 000 040 ...	M 4	6,5	0,8	6	6,2	8
338 000 040 ...	M 4	6,5	0,8	8	6,2	10
337 000 050 ...	M 5	8	1	7	7,7	9
338 000 050 ...	M 5	8	1	10	7,7	13
337 000 060 ...	M 6	10	1,25	8	9,6	10
338 000 060 ...	M 6	10	1,25	12	9,6	15
337 000 080 ...	M 8	12	1,5	9	11,5	11
338 000 080 ...	M 8	12	1,5	14	11,5	17
337 000 100 ...	M 10	14	1,5	10	13,5	13
338 000 100 ...	M 10	14	1,5	18	13,5	22
337 000 120 ...	M 12	16	1,75	12	15,4	15
338 000 120 ...	M 12	16	1,75	22	15,4	26
337 000 140 ...	M 14	18	2	14	17,4	17
338 000 140 ...	M 14	18	2	24	17,4	28
337 000 160 ...	M 16	20	2	14	19,4	17
338 000 160 ...	M 16	20	2	24	19,4	28

**Example for finding the article number**

Self-tapping threaded insert Ensat®-SBS to Works Standard 337 0 with internal thread A = M5 made of case-hardened, zinc plated, thick film passivated steel: Ensat®-SBS 337 000 050.112

**Short design**  
**Long design**

Works Standard 337  
Works Standard 338

**Materials**

Case-hardened steel, zinc plated, blue passivated  
Case-hardened steel, zinc plated, thick film passivated  
Case-hardened steel, zinc-nickel plated, transparent passivated  
Stainless steel 1.4305  
Brass

Article no. (**fourth** group of digits) ... .. 110  
Article no. (**fourth** group of digits) ... .. 112  
Article no. (**fourth** group of digits) ... .. 143  
Article no. (**fourth** group of digits) ... .. 500  
Article no. (**fourth** group of digits) ... .. 800

**Other materials, designs (e. g. fine thread) and finishes on request.**

**Tolerance**

ISO 2768-m

**Thread**

Internal thread A: as per ISO 6H  
External thread E: Special thread with flattened thread root, as per KKV standard  
Internal thread UNC, UNF, Whitworth on request

### Application

Particularly where a connecting element is required to offer a high level of resistance to acids and corrosion, the Ensats®-SBS made of the material **1.4404** provides an important missing link in the field of stainless steels.

Due to its extremely good material properties – **good resistance to most media containing chloride and non-oxidizing acids** – this threaded insert offers additional scope for application.

The three cutting bores distributed around the periphery are shaped to create a chip reservoir. The coarse chips created during the screw-in process rest there and cannot drop into sensitive collect equipment parts.

**Before application we fundamentally recommended performing tests under operating conditions, with regard to acid and corrosion resistance.**

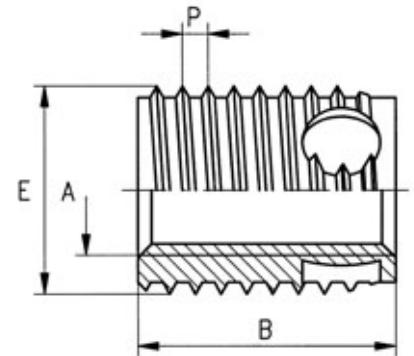

Dimensions in mm

Article number	Internal thread	External thread Special thread		Length	Borehole diameter guideline value	Minimum borehole depth for blind holes
	A	E	P	B	L -0,1	T
337 000 030 504	M 3	5	0,6	4	4,8	6
338 000 030 504	M 3	5	0,6	6	4,8	8
337 000 040 504	M 4	6,5	0,8	6	6,2	8
338 000 040 504	M 4	6,5	0,8	8	6,2	10
337 000 050 504	M 5	8	1	7	7,7	9
338 000 050 504	M 5	8	1	10	7,7	13
337 000 060 504	M 6	10	1,25	8	9,6	10
338 000 060 504	M 6	10	1,25	12	9,6	15
337 000 080 504	M 8	12	1,5	9	11,5	11
338 000 080 504	M 8	12	1,5	14	11,5	17

### Example for finding the article number

Self-tapping threaded insert Ensats®-SBS to Works Standard 337 0 with internal thread A = M5 made of, acid and rust-resistant steel: Ensats®-SBS 337 000 050.504

### Short design Long design

Works Standard 337  
Works Standard 338

### Materials

Acid and rust-resistant steel 1.4404 (optimised for machining - deviating to standard analysis)  
On request:  
Acid and rust-resistant steel 1.4404 (according to standard analysis)

**Other, designs (e. g. fine thread) on request.**

### Tolerance

ISO 2768-m

### Thread

Internal thread A: as per ISO 6H  
External thread E: Special thread with flattened thread root, as per KKV standard  
Internal thread UNC, UNF, Whitworth on request

